

Fagus-GreCon
Greten GmbH & Co. KG

P.O. Box 1243
D-31042 Alfeld-Hanover

Phone +49 (0) 5181-79-0
Fax +49 (0) 5181-79-229
E-Mail sales@grecon.com

www.grecon.com

GreCon

**WE EXTINGUISH
BEFORE YOU
GET BURNED**

GreCon

Fire
Protection

GreCon

Measuring
Technology



EN | R.03 | 2013.10
Subject to technical and country-specific modifications.
© Fagus-GreCon Greten GmbH & Co. KG

Spark Extinguishing Systems



Innovation is our Tradition.

With this maxim, we refer to our innovative company founder and my great-grandfather who founded the FAGUS shoe last factory in 1911. Even then he had the courage to engage the visionary, but unnoticed Walter Gropius, who became an internationally renowned architect, to build his factory, which today is regarded as the origin of the modern age building. UNESCO designated it as a World Cultural Heritage Site in 2011. With an extensive restoration, it is in very good condition, still in operation and owned by the family.

In 1970, our company experienced further innovation. My brother Gerd and I took over FAGUS, the shoe last production that continues operations today, and founded GreCon. Today, we are suppliers of measuring systems especially for the wood industry and fire protection systems worldwide. One of the fire protection systems is the spark extinguishing system.

In 1973, my father supplied a complete particleboard plant to Russia in which it burned several times a day. "You have to think of something" he said. We thought whether it was possible to detect sparks and to extinguish them before they cause fire or an explosion. The idea of a spark detection and extinguishment system was born.

We extinguish before you get burned.

Today, our spark detectors monitor industrial processes in about 200,000 installations around the world, not only in the woodworking industry, but also in many other production processes. This makes us proud, and it fills me with joy to see how many innovations have developed from our original idea!

Ernst Greten
Managing Director of GreCon

Why GreCon



- The GreCon spark extinguishing system was introduced as a world first for preventive fire protection in 1973
- Decades of **expert experience** in several industries
- About 200,000 installations **worldwide**
- Global service team with more than 80 service experts

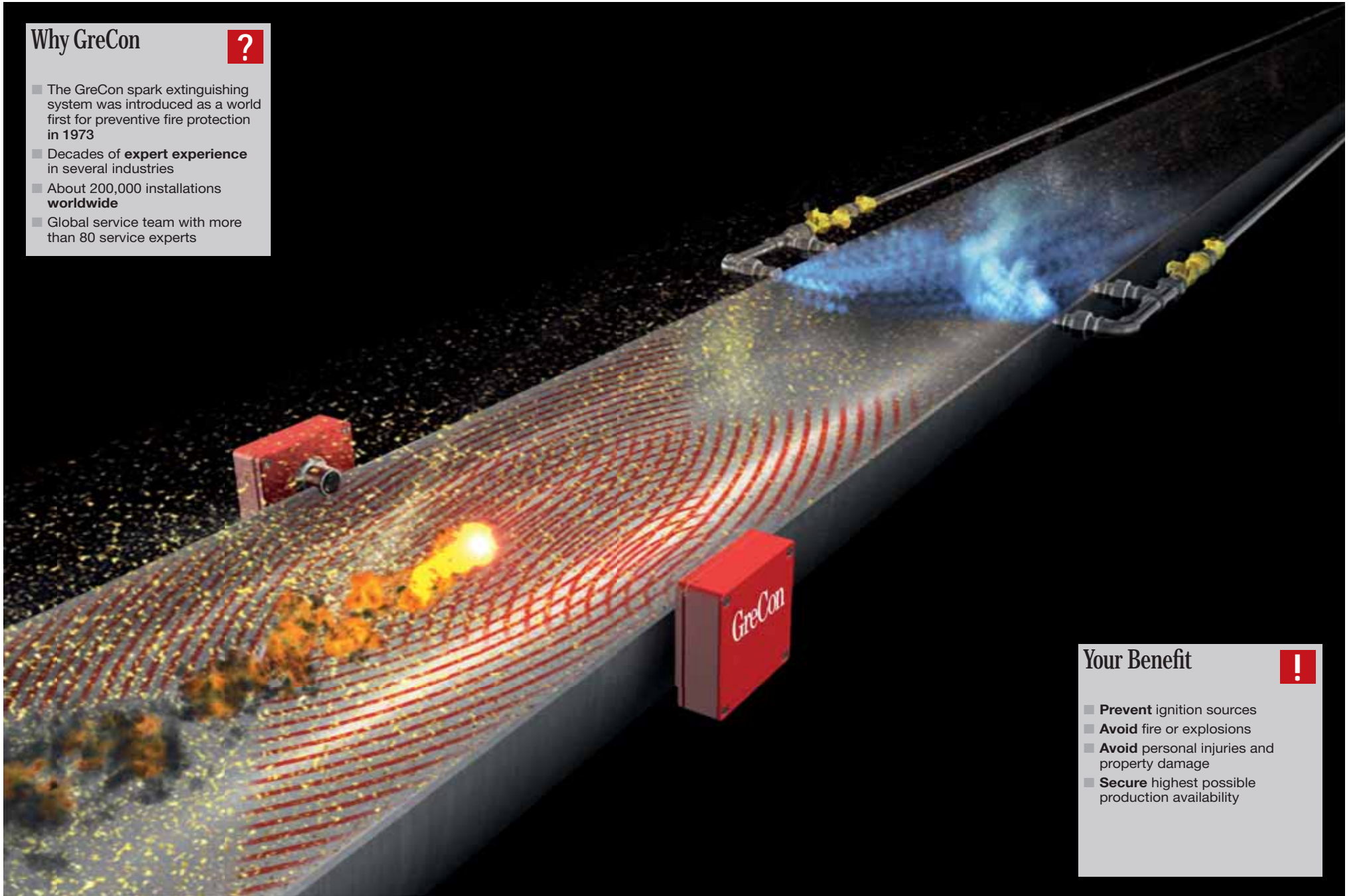

Your Benefit



- **Prevent** ignition sources
- **Avoid** fire or explosions
- **Avoid** personal injuries and property damage
- **Secure** highest possible production availability

GreCon

Detection
of Risks of Fire
and Explosion

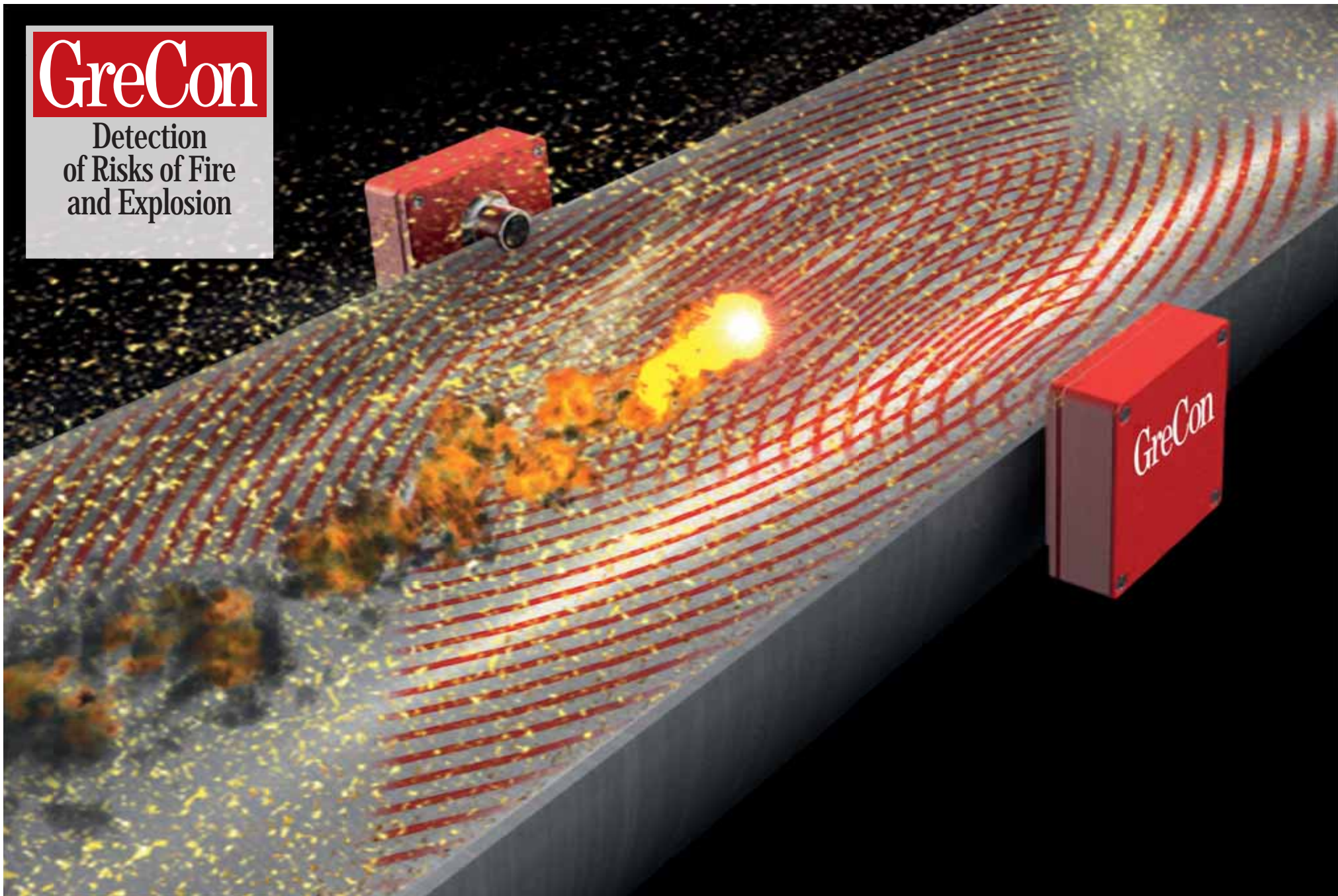

All Sensors at a Glance

There are different risks of fire and explosion in industrial processes. GreCon has suitable detectors for different risks.

Spark Detection Preferably in Dark Areas



Spark detectors FM 1/8 can be used in dark areas where ambient light is not present. This ensures the high sensitivity of the FM 1/8 sensors so that the detection of ignition sources can be optimised even in dense material flow. The optics of the sensors are normally kept clean by the air and material flow which makes the system easier to maintain.

Spark Detection in High-Temperature Areas

FM 3/8 sensors with fibre optic cables are used where processing or drying temperatures exceed 65 °C (149 °F). Three separate stainless steel covered glass fibre cables transmit the infrared radiation to the sensor, with each cable ending on a separate photo optic diode. Solid glass adapters are added to the cable end for extremely high temperatures. Detection reliability is achieved by using three detection elements per sensor. The fibre optic cables are available in different lengths for different duct diameters.



Spark Detection under Daylight Conditions



GreCon can detect sparks on conveyor belts, production lines, or at transfer points between conveyor systems.

A special sensor, type **DLD 1/8**, is used where ambient light is present.

Detection of Hot Particles and Glowing Embers



Industrial production processes often create hot materials or hot large masses without them glowing in a visible range. Such materials are, for example, coaly or sooty deposits within ducts or high volumes of comminution processes. They occur in exhaust ducts of hardening shops or foundries as well as in recycling plants. The **HPD detector** reliably detects dangerous potentials in this low, non-glowing temperature range.

Temperature Monitoring of Facilities



Thermo detectors TM 1/9 not only react when exceeding the set temperature threshold, but give an alarm upon fire-typical temperature rises. The thermo-element has two different trigger functions that work in parallel. In case of smouldering fire, i.e. slowly rising temperatures, the system heats up steadily and triggers an alarm when the nominal value of the sensor is reached. In case of quickly rising temperatures, typical of fuel fire, an alarm is triggered before the nominal value is reached.

Detection of Smouldering and Other Fire



Burning embers deeply hidden in the material release combustion gases. These gases can be detected - e.g. in a silo - by a combustion gas **detec-**

tor BGM. Combustion gas detectors can be used as stand-alone devices or in combination to monitor large areas. Smouldering fire is detected by the released gases CO, H₂, KW (phenolic hydrocarbon or nitrogen) in a ppm range. For that, the combustion gas detectors have to be installed in the area in which smouldering gases can spread. This makes fire detection possible before the gases ignite.

Detection of Open Flames



GreCon flame detectors use modern UV/IR technology for reliable detection of flames.

The UV sensor gives early alarm in case of arising fire, thus allowing early manual extinguishment.

If the fire continues to spread, the independent IR sensor will confirm the UV alarm, thus allowing reliable automatic extinguishment.

Detection of Smoke



Scattered light smoke detectors SRM 1/8 detect fires that develop smoke, e.g. in return-air ducts of dust filters. Scattered light smoke detectors can be used to detect fire in dust-free areas.

Sensor Accessories

Additional Measures against Heavy Dirt Accumulation



If dirt accumulation or other build-up on the sensor optics is expected, special **air purge adapters** increase the detection reliability. Cleaning intervals are thus extended.

Light Intrusion



Light intrusion, whether artificial or daylight, might have a negative effect on the infrared radiation detection in the sense of the application. **Slotted diaphragms** are used to avoid false alarms and to optimise the detection performance.

GreCon

Extinguishment
and Diversion of
Risks of Fire and
Explosion

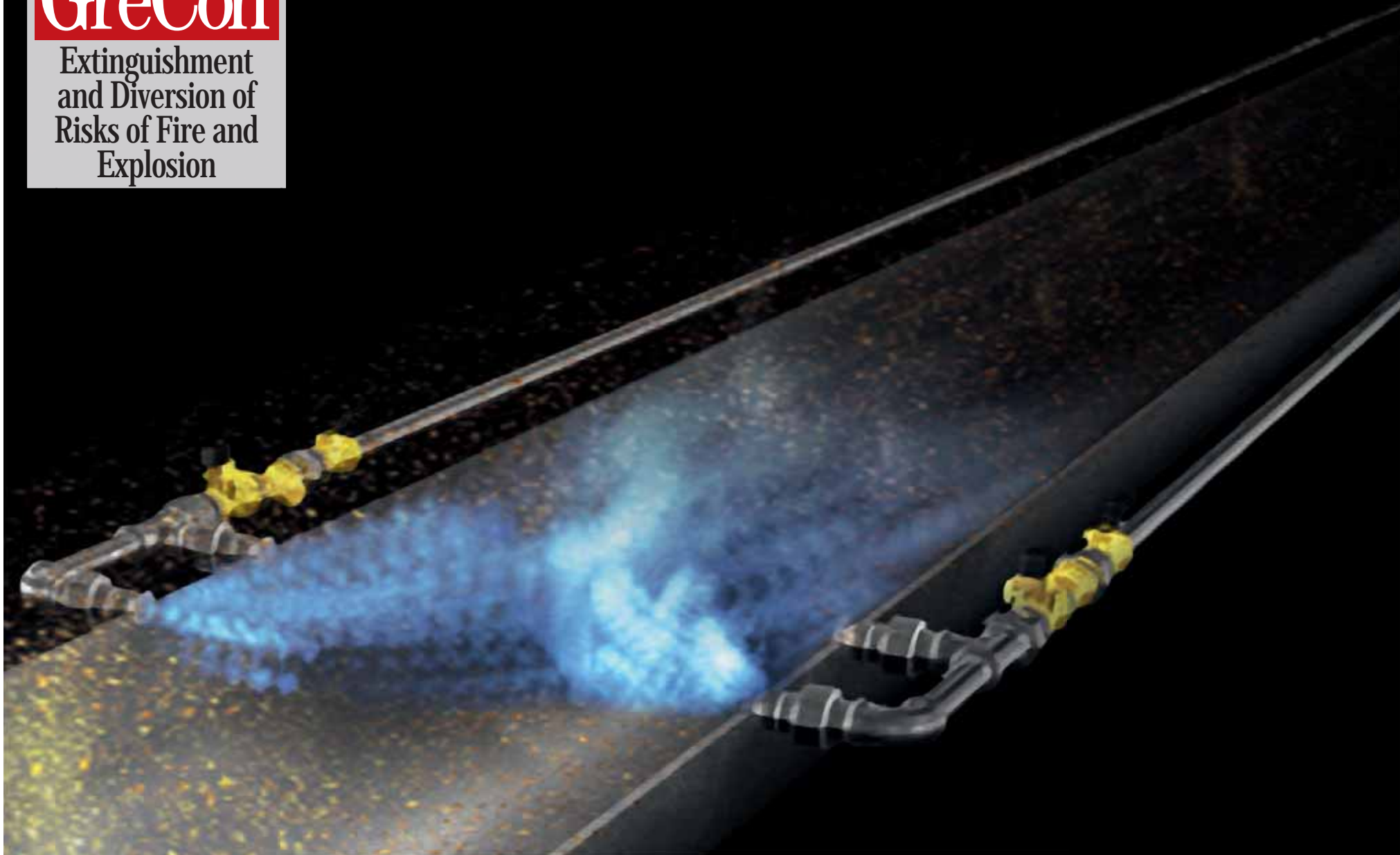

Countermeasures at a Glance

To achieve a preventive fire and explosion protection effect, automatic countermeasures are used in connection with detection.



Extinguishment

A fine water mist spray emerges from the **extinguishing nozzles** within a few milliseconds and is used for extinguishing ignition sources. They are made of high-quality stainless steel, which increases the resistance to wear. After extinguishment, the shutter cone of the nozzle automatically seals it and keeps it free of contamination. Using different nozzle types minimises the necessary water quantity.

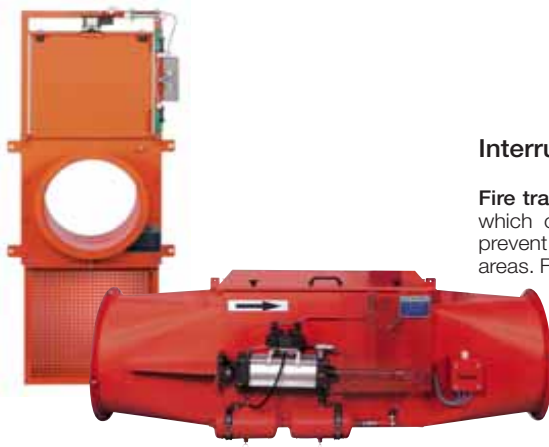

Reduce Reaction Times by a Factor of Two or Three

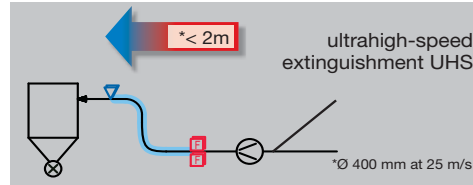

The new **ultrahigh-speed extinguishment UHS** consists of a special high-speed solenoid valve as well as special spray nozzles that are adapted to this system. GreCon now offers a solution for those areas of short pipe distances.

With the ultrahigh-speed technology, extinguishing distances of less than 2 m become possible.

Diversion of Material Flow

Diversion gates can divert the material flow to prevent the transfer of ignition sources to other plant areas. Diversion gates are also available in stainless steel for applications in the food and other industries.

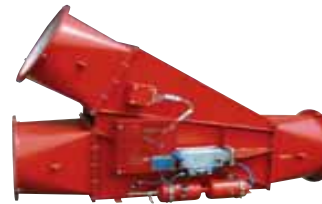

Interruption of Material Flow

Fire traps and shut-off gates are accessory parts which can mechanically close transport ducts to prevent the transfer of ignition sources to other plant areas. Fire traps and shut-off gates are also available in stainless steel for applications in the food and other industries.

Alternative Extinguishing Concepts

On demand, **special application-specific extinguishing concepts** with gas, foam or steam can be used in connection with our system.

Accessories

Pressure Increasing Units

If the available water flow pressure for extinguishment is inadequate, a **water pressure increasing unit** is installed to create the required water pressure. If the water flow rate to the pressure increasing pump is too low, or, if the unit is connected to a drinking water supply, a storage tank must also be installed.



Anti-Freeze Protection

Heat tape and insulating material can be used to **protect water pipes** and extinguishing devices from freezing in areas exposed to frost. We offer special, easy to maintain insulating bags for the extinguishing devices.



GreCon

Control Console and Operation



Multi-Touch Panels for Fast and Easy Operation of Spark Extinguishing Systems

The new 10" colour display with multi-touch function enables you to quickly call up desired information in a self-explaining and compact way from different levels of the GreCon control console. Thus, it will be quite easy to have all information available. Not only data that is available quickly after an alarm, but also long-term information from deeper levels can be shown on the display. The possibility to represent complete flowsheets is especially emphasised. Areas that have current alarms can be examined more closely by using the simple zoom function.

Important Information Available Quickly

Important data can be displayed quickly by direct selection of information via clear symbols. The display memory offers room to store electronic files, such as instruction and operating manuals, which can be used when a paper printout is not available.

Easily Retrofit Existing Systems

In many cases, the ease of operations of the multi-touch display can replace the existing standard GreCon control console display.

Operation Panel for Small Control Consoles

Small GreCon control panels are equipped with standard operation panels.



The new multi-touch display for easy and intuitive operation

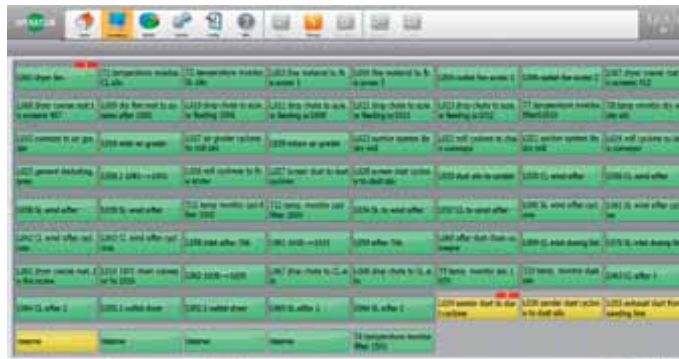

BS 7 NET makes clear operation and control from the control station possible

BS 7 NET for Easy and Clear Handling

BS 7 NET allows local installation of control consoles of the CC 7000 and CC 5000 series on the company premises, e.g. in control rooms. No space is required in control stations, and cable distances can be reduced to a minimum. The decentralised architecture provides additional redundancy and increases easy maintenance of the entire system. The control console can be placed even closer to production.

BS 7 NET is a simple operation and visualisation possibility of the current incidents in the system. The operation staff can react to current alarm incidents much faster. The easy handling can simplify the operation of spark detection and extinguishment systems in daily life.

Essential operation are, for example, the acknowledgement of alarms or the clear administration of disablings. The BS 7 NET server collects all information and communicates with the control consoles and the operation clients that might be installed in different production sections. One can see at a glance where danger zones are concentrated and whether interventions are necessary.

BS 7 NET displays alarm frequencies and records the events of all control consoles with a time stamp exactly to the millisecond. Management and operator are always up to date.

Data can be exchanged with the customer's control systems via gateways to Profibus, Profinet or DeviceNet.

BS 7 NET System Survey

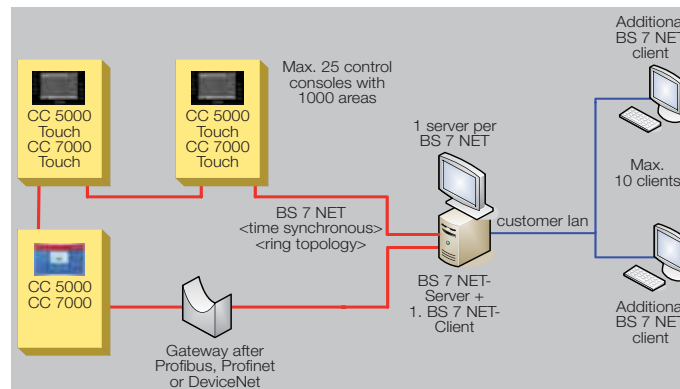



GreCon

Global
Service Team
with more than
80 Experts

Personal customer service, combined with competence and experience, is our strength

Customer service is one of our strengths. Beginning with the installation and start-up of your system, its daily use, maintenance work and troubleshooting, your personal GreCon technician accompanies your spark extinguishing system and/or your inline measuring systems through its whole operational sequence. This is done in close cooperation with your people.

Our Network



Over 10,000 production plants in hundreds of industries worldwide are protected by GreCon spark extinguishing systems.

To meet this extensive use of our systems and the customers behind them, we are represented by our own companies and reliable partners worldwide.

GreCon
QUALITY
INNOVATION
TRADITION

